

TECHNICAL SPECIFICATIONS ROCKWHEEL G125

The Hydraulic Cutting Unit Rockwheel G125 can be supplied with either scaling/grinding or rock cutting drums.

Hydraulic Power	400 kW
Maximum Oil Flow	1.000,0 l/min
Optimum Oil Flow	800,0 l/min
Maximum Pressure	400 bar
Reduction ratio	1,23 :1
Cutter Torque	137.160 Nm @ 350 bar
Pick Force	296,4 kN @ 350 bar
Drum Speed	40,6 rpm @ 1.000 l/min
Pick Speed	1,96 m/s @ 1.000 l/min
Operating Weight	5.420 kg
Excavator Size	70 - 125 t
No. of Picks	76 (38/30 mm Stepped Shank)

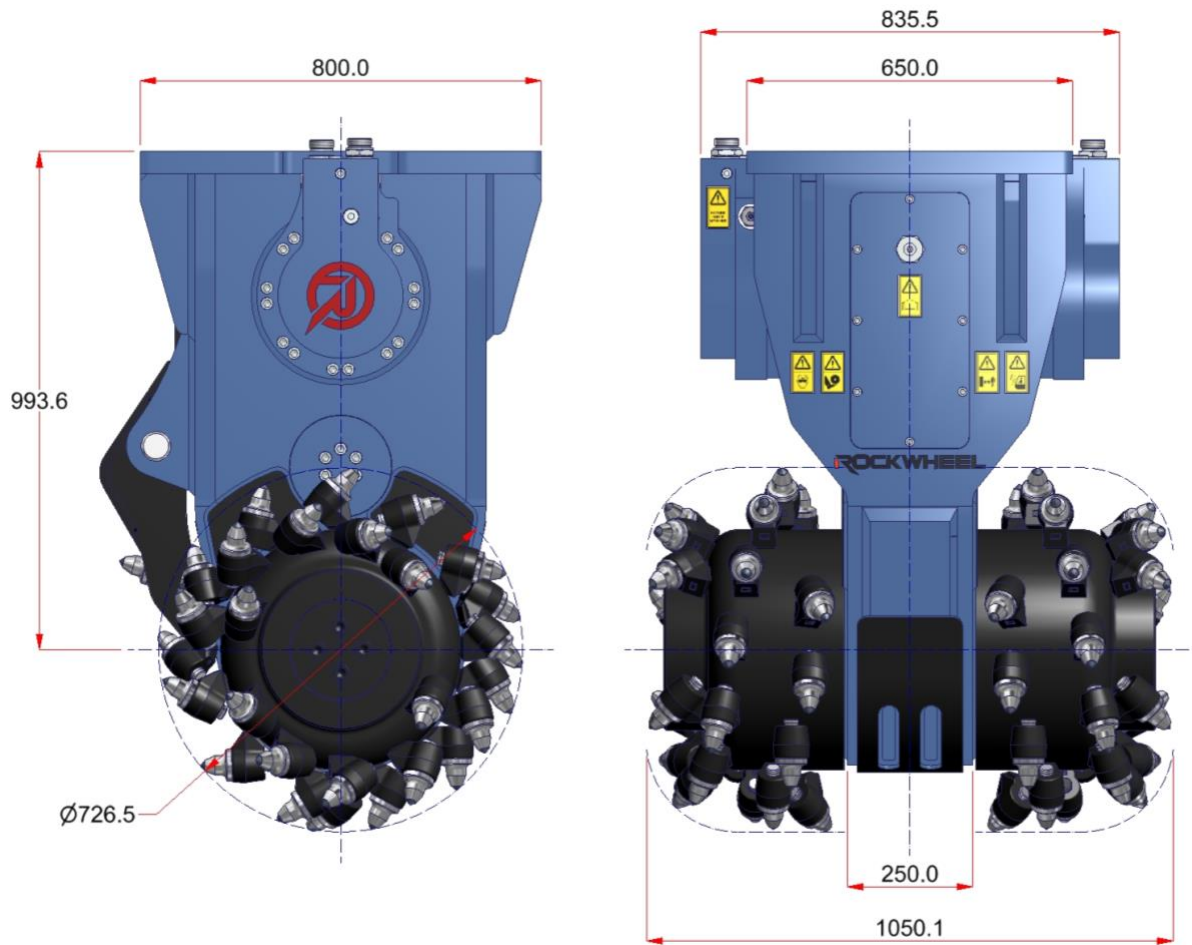



Rockwheel Cutting Units are designed and patented by Webster Technologies Ltd., UK.